

**PAPUA NEW GUINEA PUBLIC SERVICE****JOB DESCRIPTION****1. IDENTIFICATION**

AGENCY: Department of Prime Minister & NEC	SYS. POSN. NO: 0000450039	REF. NO: LO 10	
WING: Policy Coordination & Monitoring	DESIGNATION/CLASSIFICATION: Research Officer – Grade 14		
DIVISION: LOSA & PDS	LOCAL DESIGNATION: Research Officer – Justice, Police, Defense & CIS		
BRANCH: Law and Sector Sector	REPORTING TO: Snr. Policy Coord. Monit. Off (Police)	SYS. POS. NO: 0000450040	REF. NO: LO 07
SECTION: Justice, Police, Defense & CIS	LOCATION: Waigani		

HISTORY OF POSITION

FILE REF.	DATE OF VARIATION	DETAILS
Org: 02/2016	8 th April, 2016	Abolished/Created

2. PURPOSE

To provide comprehensive research and administrative support to the Senior Policy Coordination & Monitoring Officer (Justice, Defence & NCM) in all matters relating to coordination of policy development, implementation and reporting.

3. DIMENSIONS

- To provide assistance to the Senior Policy Coordination Monitoring Officer and Director (Justice, Defence, Police, and CIS etc) to conduct high level research or any other tasks as instructed by the Chief Secretary from time to time.

4. PRINCIPLE ACCOUNTABILITIES

- Effective design, coordinate and conduct policy – relevant research on other aspects of Law & Order, Justice Sector, as agreed by the Director – Law & Order, Justice Sector, and with a likely focus on exclusion issues
- Proper administration and development, implementation and evaluation of research projects
- Effective design, coordinate and conduct policy – relevant research and development phase of new projects to ensure the project meets with clients expectations
- Ensure compliance with Law & Order, Justice Sector procedures.

5. MAJOR DUTIES

- Conduct research and coordinate to influence policies and practices of governments, NGOs, with particular focus on Law & Order, Justice Sector peace building

- (b) Collect, analyze and collate respective sector unit performance reports on a periodic, monthly, quarterly, half yearly and annual basis;
- (c) Advice and guide concerned departments and agency on policy development including strategic plans to be aligned synchronized and harmonized with National Coordination Mechanism (Law & Order, Justice Sector) , National Strategic Plan and MTDP;
- (d) Develop and maintain relations with key stakeholders and interlocutors in order to build networks.
- (e) Write research reports designed to influence the policy and practice to peace builders and of others with an influence on the prospects for peace.

6. NATURE AND SCOPE

The position is within the Law & Order – Justice Sector of the Department and reports to the Director – Just, Police, Defense & CIS through the Senior Policy Coordination & Monitoring Officers. The position reports on operational activities, specifically on the Law & Order – Justice Sector issues and concurrent developments. The position may report to the Director General - Just, Police, Defense & CIS as and when it is necessary.

6.1 WORKING RELATIONSHIP (draw structure)

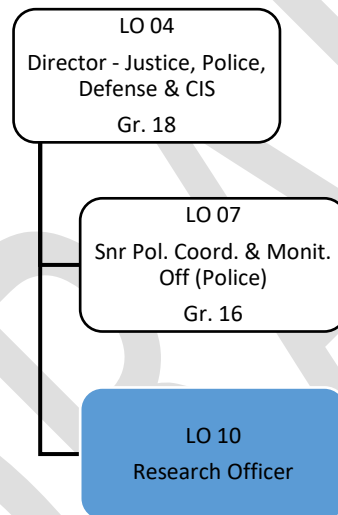

(a) Internal

The Research Officer reports to the Director – Just, Police, Defense & CIS through Senior Policy Coordinator & Monitoring Officers and provides researched data reports, information and support to the team members and supervisors on the law & order – justice sector issues. The position requires the incumbent to establish working relationship and dialogue with the counterparts.

(b) External

On request by the supervisors liaise with Department of Police, Department of Defense, Department of Justice, Department of CIS, relevant Government Department and Agencies for information and data gatherings.

6.2 WORK ENVIRONMENT

The position is administrative and is located in Waigani however, when required, official visits to government agencies within and outside of National Capital District relating to the job is evitable.

7. CONSTRAINTS FRAMEWORK AND BOUNDARIES

Rules/procedures

- The position is guided by the Public Service General Orders, Public Service Finance (Management) Act and the Employment Act.
- Constraints will be due to amendments to policies and legislations and restrictions imposed through government circulars and instructions.
- Maintain high level of confidentiality of information
- Maintain high level of work ethics and professionalism

Decision

- This position does not make decisions but only take directives from the senior officers within the Just, Police, Defense & CIS Sector.

Recommendations

- Any recommendations made by this position should align with NEC Decision, relevant legislations pertinent with coordinating implementation of Donor Funded Activities and Department internal policies. Recommendations are forwarded to the office of the Director – Justice, Police, Defense & CIS through Senior Policy Coordinator & Monitoring Officers.

8. CHALLENGES

- Ensure quality Research findings and maintaining compliance with modern requires technique and skills.
- High level of communication with stakeholders in providing administrative support and promoting service is a challenge to the sector in terms of policy planning, establishing sector priorities and implementation against scarcity of resource and reporting.

9. QUALIFICATIONS, EXPERIENCES AND SKILLS

(a) Qualifications

Must hold a first degree in Public Policy, Politics, Admin, Development Planning & Administration, Legal Studies or Social Science.

(b) Knowledge

- (i) Knowledge of the PSM Act, GO, PMNEC Act, sound knowledge of relevant laws and legislations;
- (ii) Qualitative and quantitative methods of research and analytical report writing
- (iii) Proven high written and verbal communication skills including the ability to produce comprehensive professional written documents of an outstanding quality report.
- (iv) Research Designs & Methodologies

(c) Skills

- Empirical Research, data analysis and in writing evidence – based reports and practical recommendations
- Computing skills, Ms Word, Excel, etc
- Practical and theoretical understanding of peace building, including how law & order is integrated into peace building
- High level of organization and planning skills
- Presentation skills

(d) Work Experience

Minimum of four (4) years working experience in a similar position within the Public Service or the private sector.

DRAFT